

WIDE TRACK 50 SLOT DIFFUSER



HIGH CAPACITY SINGLE SLOT DIFFUSER



High Capacity Single Slot Diffuser

WT50

WT50 linear slot diffuser offers a truly discrete appearance for the discerning interior designer which blends into it's surroundings perfectly offering a unique high quality and subtle appearance.

WT50 can be installed in walls or bulkheads for vertical discharge with directional supply.

WT50 can be used for supply and extract.

Various flange options are available including surface-mount with either 25mm or 32mm flanges.

The plaster-in frame offers the most discrete mounting option with only the air gap visible when fully installed.



WT50 Coffered Installation

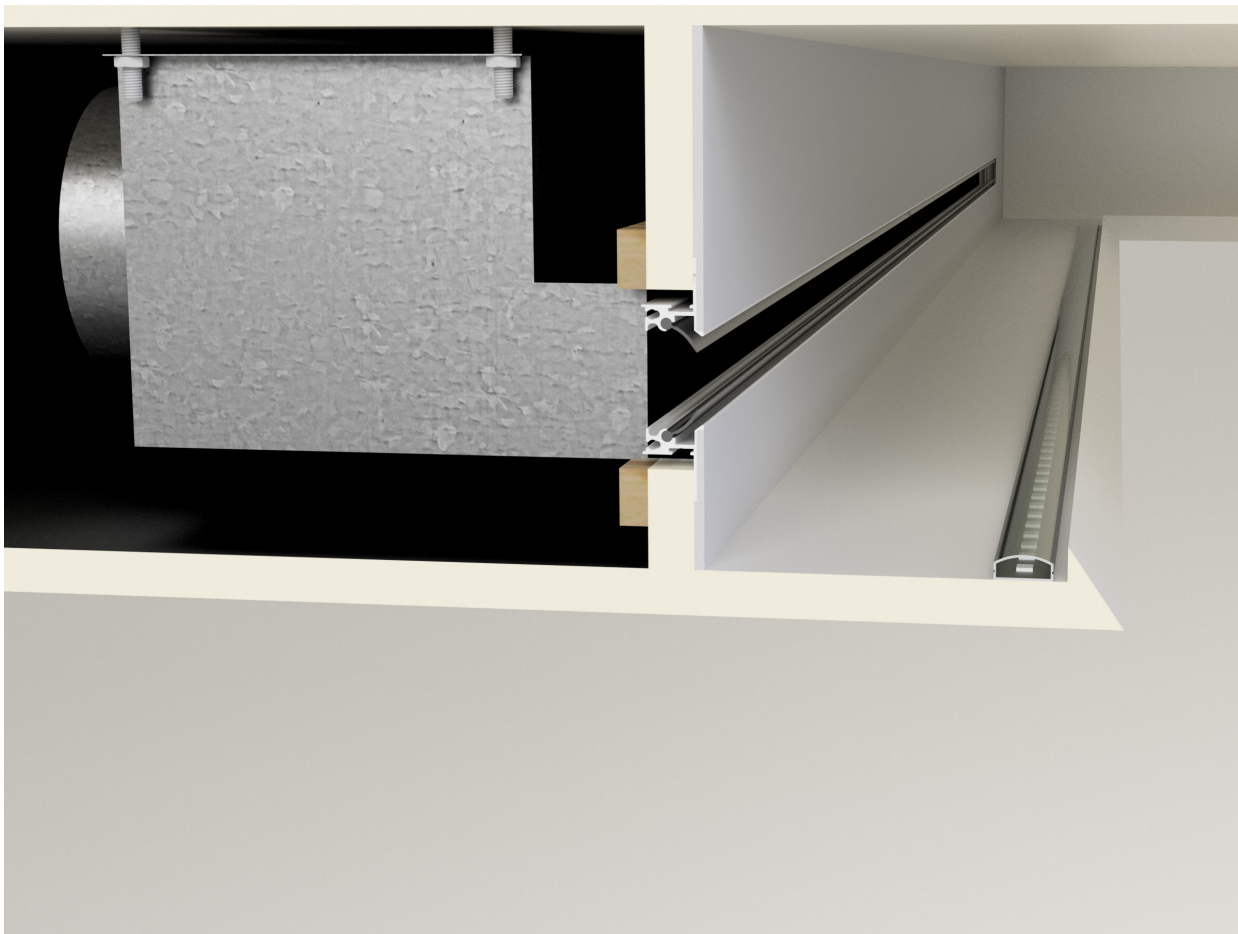

Specification

Material

Extruded aluminium.

Blade Options

Extruded aluminium in black or powder coated to client spec.

End Flanges

Welded end flanges are supplied as standard. Fitted on both ends for single pieces. Linear runs will be supplied with 1 end flange on each end piece. Make-up pieces will be open-ended.

Fixing

Multi-purpose 'U' bracket fixing allows for fitting to a hemmed-edge plenum box and also to plasterboard ceiling.

Width

1 Slot, 50mm width

Length

Individual sections up to 1800mm made in one piece. Linear runs are supplied in 1800mm long sections with end flanges as necessary. Exact lengths will be achieved with intermediate make-up sections, sized to suit.

Mitred Corners

Mitred corner sections are available as standard in 90° sections. Other angles and configurations are available, templates or drawings will be required.

Special Frames

Special frame arrangement can be manufactured to suit most applications, please call the Sales Office to discuss your requirements.

Flange Styles

25mm Surface Mounted

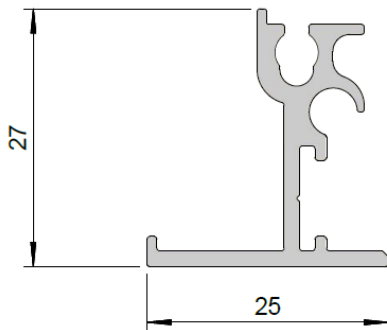

32mm Surface Mounted

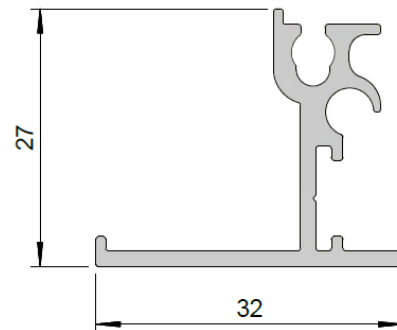

31mm Plaster-in

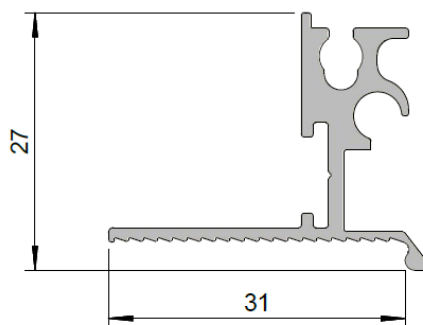

25mm Plaster-in (removable core)

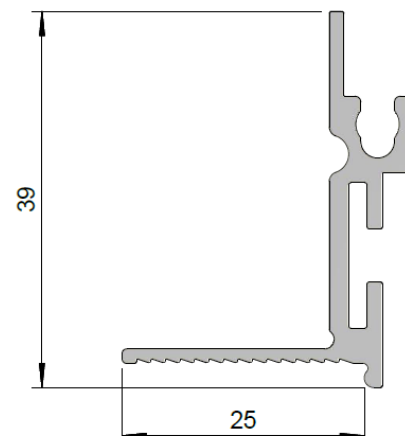

Dimensional Information

25W FRAME

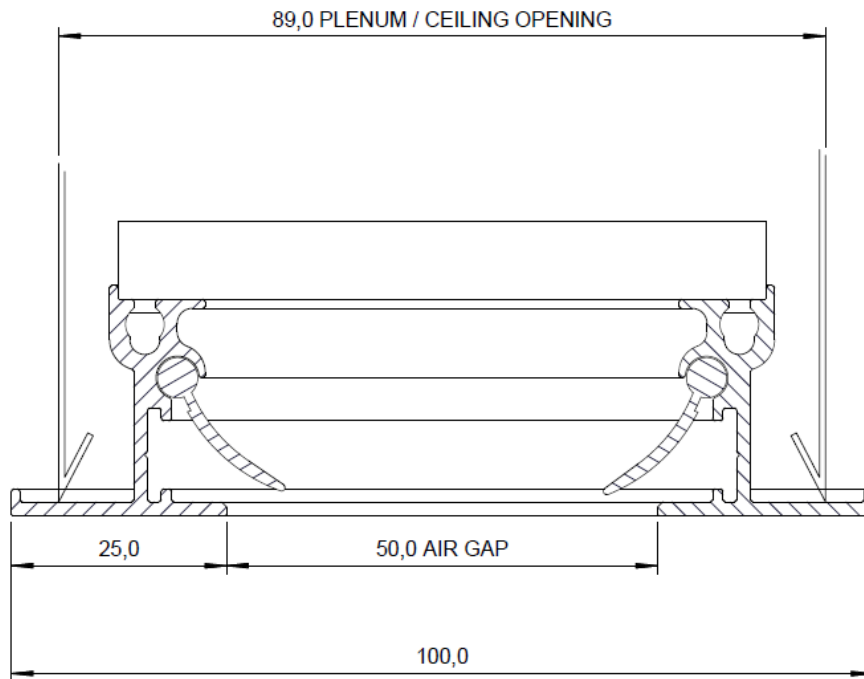

32W FRAME

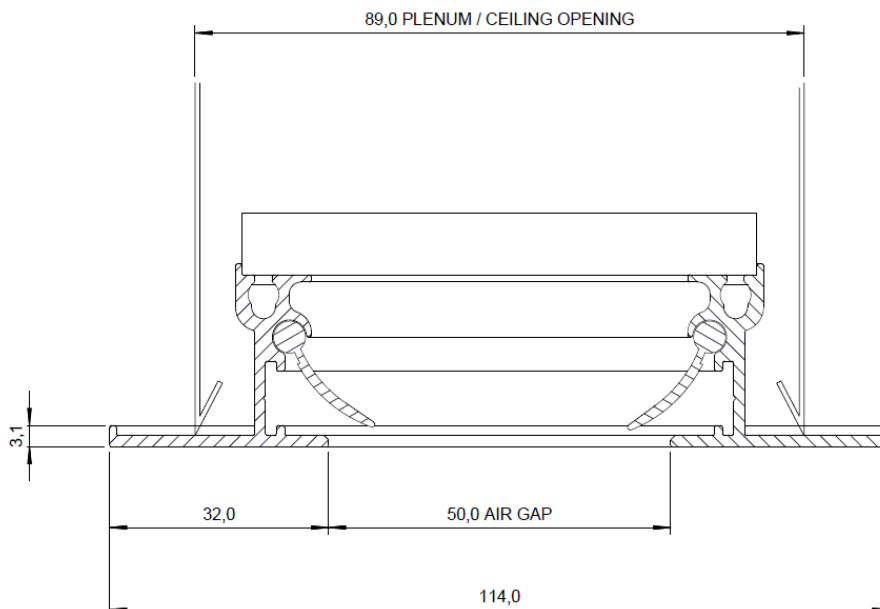

Dimensional Information

31P FRAME

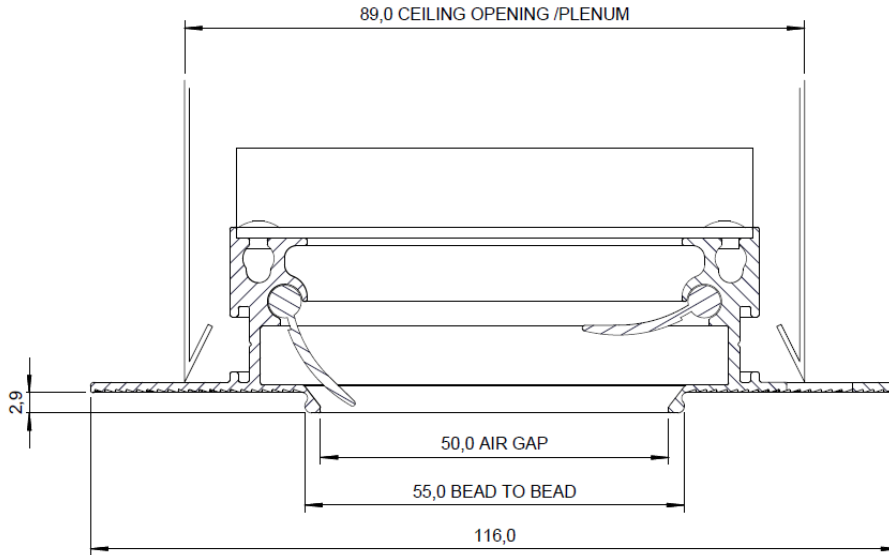

25P-25W FRAME

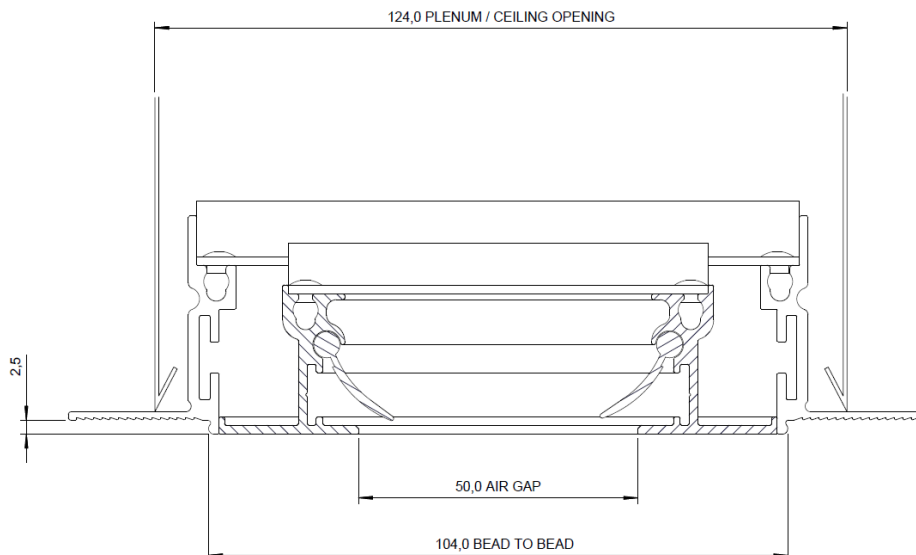

WIDE TRACK 50 SLOT DIFFUSER

Selection Nomogram for Vertical / Sidewall Throw in Free Space

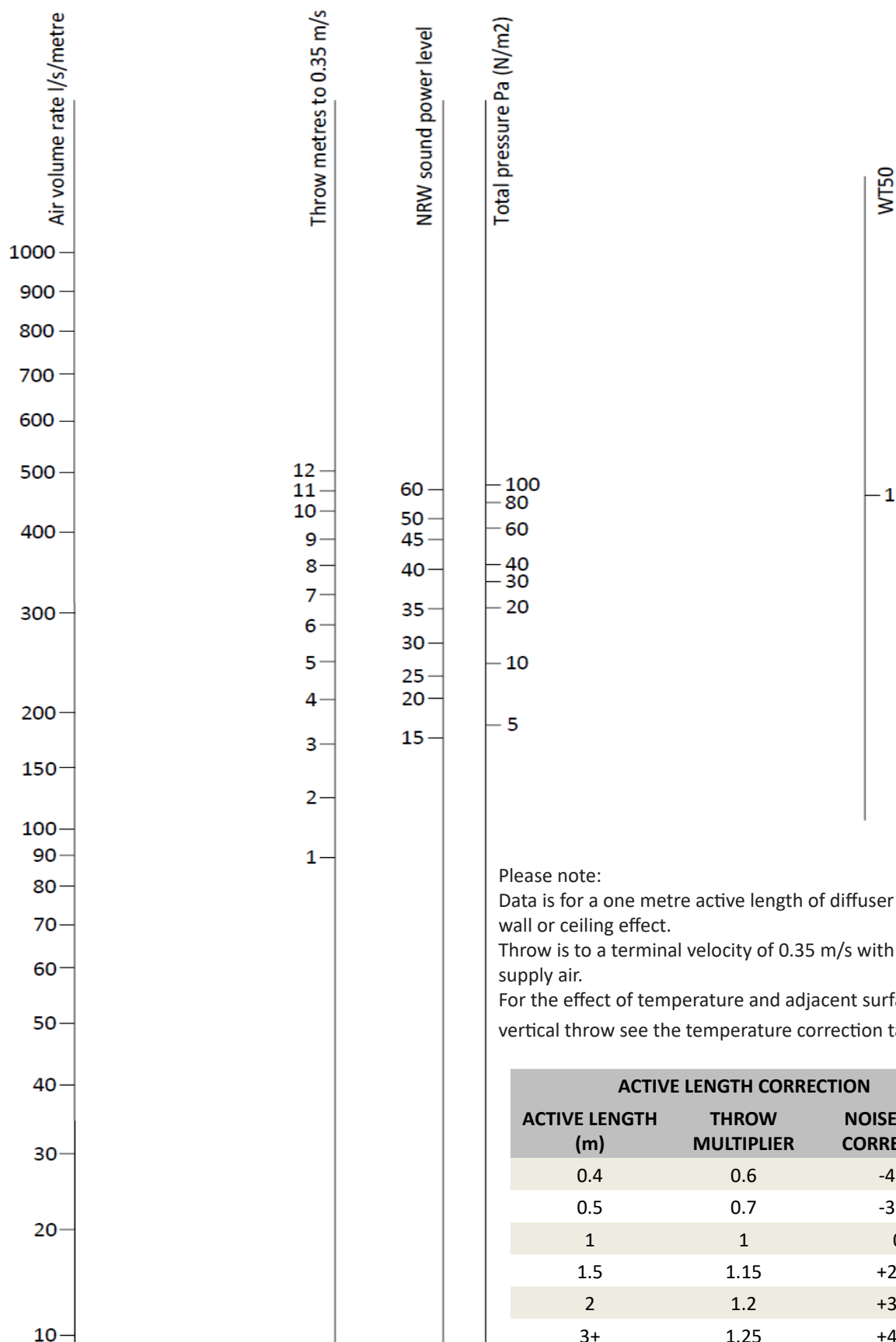

Please note:
 Data is for a one metre active length of diffuser with no wall or ceiling effect.
 Throw is to a terminal velocity of 0.35 m/s with isothermal supply air.
 For the effect of temperature and adjacent surfaces for vertical throw see the temperature correction table below.

| ACTIVE LENGTH CORRECTION | | |
|--------------------------|------------------|------------------------|
| ACTIVE LENGTH (m) | THROW MULTIPLIER | NOISE LEVEL CORRECTION |
| 0.4 | 0.6 | -4dB |
| 0.5 | 0.7 | -3dB |
| 1 | 1 | 0 |
| 1.5 | 1.15 | +2dB |
| 2 | 1.2 | +3dB |
| 3+ | 1.25 | +4dB |

Linear Slot Diffuser Selection Procedure

Data

1. Horizontal projection with ceiling effect nomogram readings are based on 10 degrees cooling application. Use this nomogram for horizontal projection ceiling mounted diffusers or horizontal projection wall mounted diffusers with ceiling effect.
2. Vertical /sidewall projection nomogram readings are based on isothermal conditions in free space without wall effect. For supply / room temperature differential for vertical throw applications from ceiling see 'Vertical throw multipliers for differential temperatures' table.
3. Use vertical/sidewall projection nomogram readings for sidewall supply application in free space. Please note that throw values apply to isothermal conditions only and technical advice should be sought before using this method of supply for heating or cooling.
4. Nomograms are based on 1.0 metre active slot lengths. For other active slot lengths see correction table.
5. Pressure drop and sound power level readings obtained from nomograms are for slot diffusers only.
6. For pressure drop additions and sound ratings for plenum boxes see separate table.
7. When using slot diffuser in extract applications select performance using vertical/sidewall projection nomogram and ignore throw values.
8. Sound values given for plenum boxes are approximate only and dependent on spigot entry conditions. Where sound requirements are critical acoustic lining of plenum boxes should be considered. Any space requirement to accommodate lining material must be added to selected box size.

Selection Procedure

The method set out below used in conjunction with the tabulated data allows slot 50 linear diffusers to be selected for supply or extract modes in either ceiling or sidewall applications. Air pattern is determined by the position of the pattern control blades.

Method – Slot Diffuser

1. Establish volume flow rate per metre by dividing total air volume by the active slot length to give litres/metre.
2. Using appropriate nomogram place a straight edge through the volume as calculated and position to pass through required throw value with satisfactory noise and pressure readings. Select suitable slot width and number of slots where straight edge passes through slot selection line. Finally realign straight edge through volume and slot selected points and read exact throw, sound and pressure figures.
3. Readings obtained from the above using uhorizontal ceiling nomogram are based on 1 metre active slot length. (See note on nomogram) For other active lengths see "Active Length Correction Table" for throw multiplier and sound level adjustment.
4. Readings obtained from the methods above using vertical / sidewall projection, nomogram are based on isothermal conditions. For vertical throw values for temperature differential see "vertical Throw Multipliers For Differential Temperatures" correction table to obtain throw multiplier for varying number of slots.

Method -Plenum Boxes

1. Determined volume of plenum box by multiply chosen length of box x volume/metre of slot. (A maximum box size of 1.8mm long is recommended)
2. Select plenum spigot size from selection table a maximum entry velocity of 3.5m/sec is recommended. Velocities in excess of this may lead to noise generation.

3. From table of "Plenum Box Pressure Drops and Sound Ratings" read off additional pressure drop to be added to slot diffuser pressure drop from nomogram. Ensure that plenum box sound power level is no more than slot diffuser reading if latter is design criteria.
4. Where it is not possible to accommodate standard plenum boxes, special configurations are available, but should always maintain an equivalent cross-sectional area to a standard box, consideration should also be given to the inlet spigot in respect of positioning, sizing and inlet velocities. Consult our technical department for detailed advise.

Commissioning

Calculation
Volume $9m^3/s =$
Av. Measured velocity (m/s) x active length (m) x number of slots x flow factor.

The flow factor is simply the width of the slot in metres at the point where the velocity is measured.

Velocity Measurement

To measure the velocity, it is important that an instrument with a measuring head small enough to fit the blade opening is used. The most suitable instrument is a hot wire anemometer. Take velocity readings at the blade openings at a maximum of 150mm centres along the active length to obtain an accurate average velocity and use this value in the formula above.

Exhaust

Procedure same as supply but with the anemometer probe reversed.