

Our Polycarbonate Floor Swirl Diffuser is suitable for use in raised floor air distribution systems. The pattern of the diffuserplate is designed to achieve high induction rates of room air which optimizes mixing for maximum comfort conditions but very importantly, achieves low plenum pressure. The dust collection basket is removable for cleaning and acts as a hit and miss damper. Supplied in Grey RAL 7037 as standard.

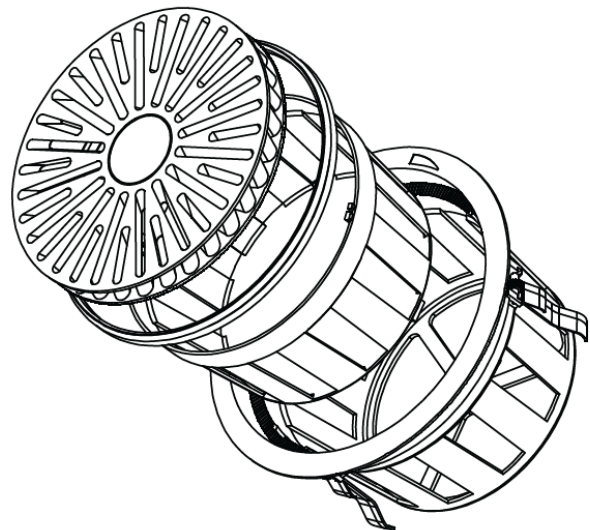

## Diffuser Dimensions

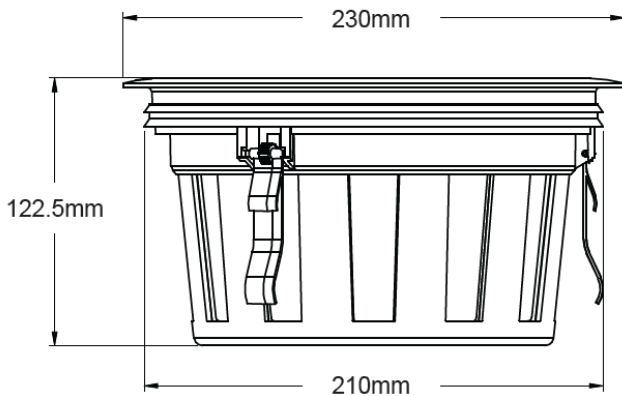

## Performance Data

<b>Air Volume l/s</b>	10	15	20	25	30	35	40	45	50	55
<b>Pressure Drop Pa</b>	2	3	5	8	11	14	17	22	27	32
<b>Noise Level NC</b>						11	13	15	18	20
<b>Vertical Projection (m)</b>	0.3	0.4	0.6	0.9	1.1	1.3	1.5	1.8	1.9	2.0
<b>Horizontal Spread (m)</b>	0.3	0.5	0.6	0.8	1.3	1.7	1.8	1.7	1.7	1.7

Data based on ceiling height of 2.7m and a 5° differential between supply air and averaged occupied zone temperature. Damper fully open.